

Montageanleitung

90mm BI LED Modul

Installation Instruction

90mm BI LED Module

Instructions de Montage

90mm BI LED Module

Monteringsanvisning

90mm BI LED Modul

Montagehandleiding

90mm BI LED Module

Instrucciones de Montaje

90 mm BI Módulo LED

Istruzioni di Montaggio

90mm BI LED Module

Asennusohje

90mm BI LED Module

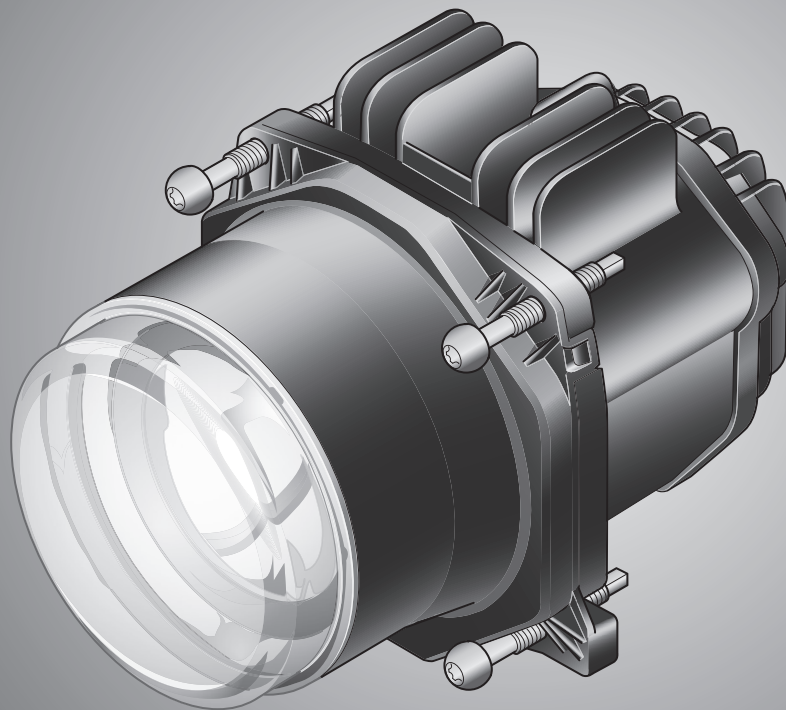

DE Technische Änderungen vorbehalten

EN Subject to alteration without notice

FR Sous réserve de modifications techniques

SV Vi reserverar oss för tekniska ändringar

NL Technische wijzigingen voorbehouden

ES Reservadas modificaciones técnicas

IT Con riserva di modifiche tecniche

FI Oikeus teknisiin muutoksiin pidätetään

Zeichenerklärung
Explanation of symbols
Explication des symboles

Symbolförklaring
Legenda
Aclaración de símbolos

Legenda
Piirroksen selitys



- DE** Richtig
- EN** Correct
- FR** Correct
- SV** Rätt
- NL** Goed
- ES** Correcto
- IT** Giusto
- FI** Oikein



- DE** Falsch
- EN** Incorrect
- FR** Incorrect
- SV** Fel
- NL** Fout
- ES** Erróneo
- IT** Sbagliato
- FI** Väärin



- DE** Positionspfeil
- EN** Location/Position Arrow
- FR** Flèche de Position
- SV** Positionspil
- NL** Lokatie/Positie pijl
- ES** Flecha de posición
- IT** Freccia di posizione
- FI** Paikannusnuoli



- DE** Bewegungspfeil
- EN** Movement Arrow
- FR** Flèche indiquant sens du mouvement
- SV** Rörelsepil
- NL** Richtingspijl
- ES** Flecha de movimiento
- IT** Freccia di movimentov
- FI** Liikesuuntanuoli



- DE** Achtung
- EN** Warning
- FR** Attention
- SV** Varning
- NL** Let op
- ES** Atención
- IT** Attenzione
- FI** Huomio

**Lieferumfang
Kit Includes
Fourniture**

**Leveransomfattning
Inhoud Set
Volumen del Suministro**

**Dotazione di Fornitura
Osaluettelo**

**1AL 010 820-02X
1LL 010 820-03X**

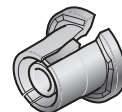
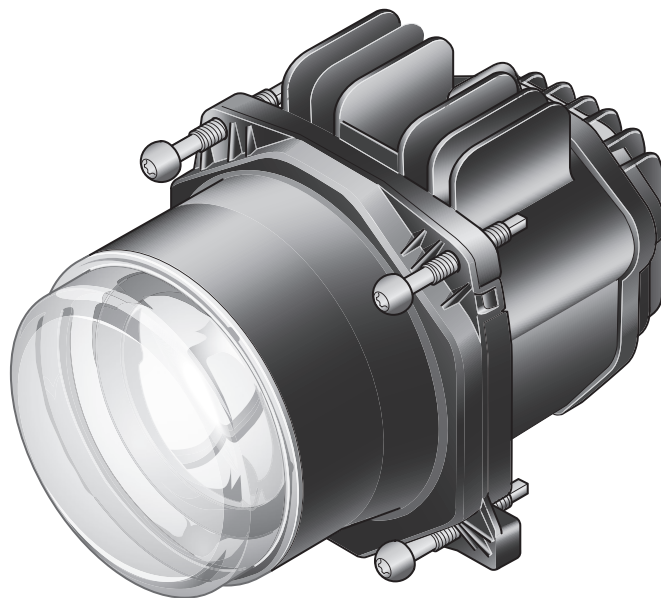

3x



3x

Zubehör
Accessories
Accessories

Tillbehör
Toebehoren
Accessorios

Accessori
Lisätarvikkeet

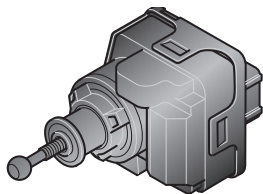

6NM 007 282-221 (12V)
6NM 008 299-501 (24V)



8HG 138 619-007



8HG 138 620-007

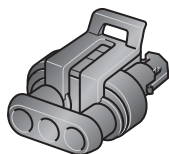

8JA 746 184-032



8KW 744 837-002



9GD 746 185-002



9AH 169 580-011

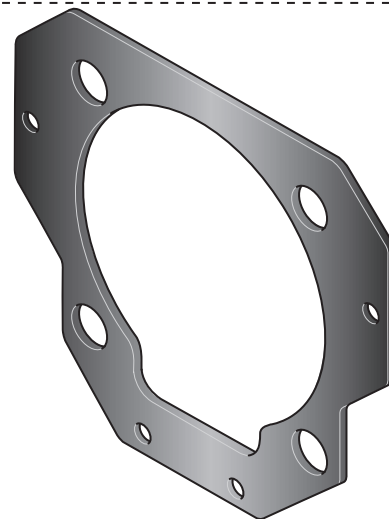
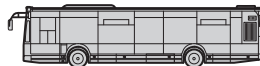

9AH 185 978-011

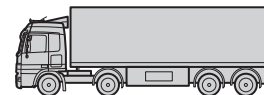

Benötigte Montagewerkzeuge
Installation tools required
Outillage de montage requis

Nödvändiga monteringsverktyg
Benodigde montagewerktuigen
Herramientas de montaje necesarias

Attrezzi necessari per il montaggio
Tarvittavat asennustyökalut

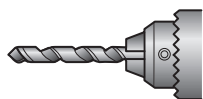
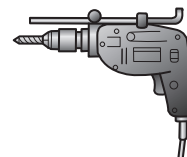
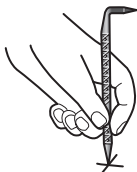
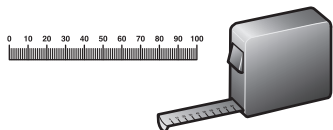

3,5 mm
5 mm
6,5 mm

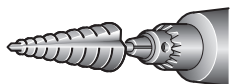

14 mm
16 mm
17 mm
24 mm

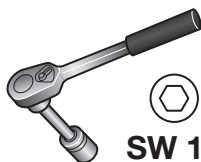
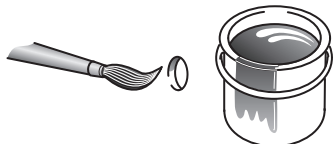

SW 10



Torx 20



Montage
Mounting
Montage Général

Montering
Montage
Montaje

Montaggio
Asennus

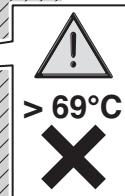
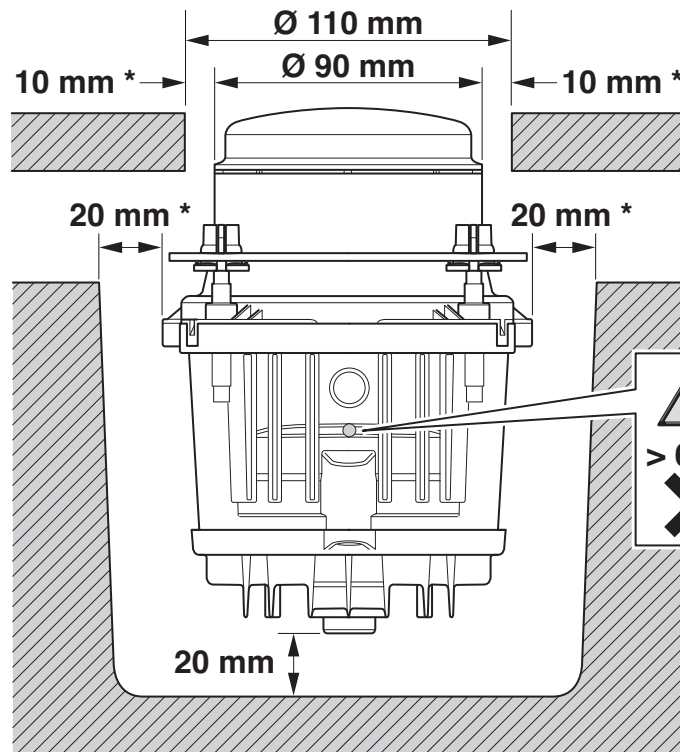
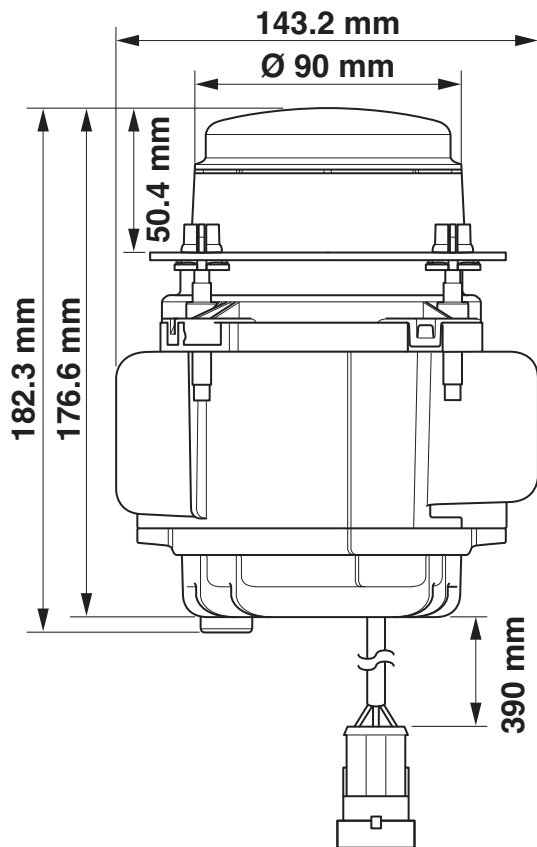

*  32, 33

1:1

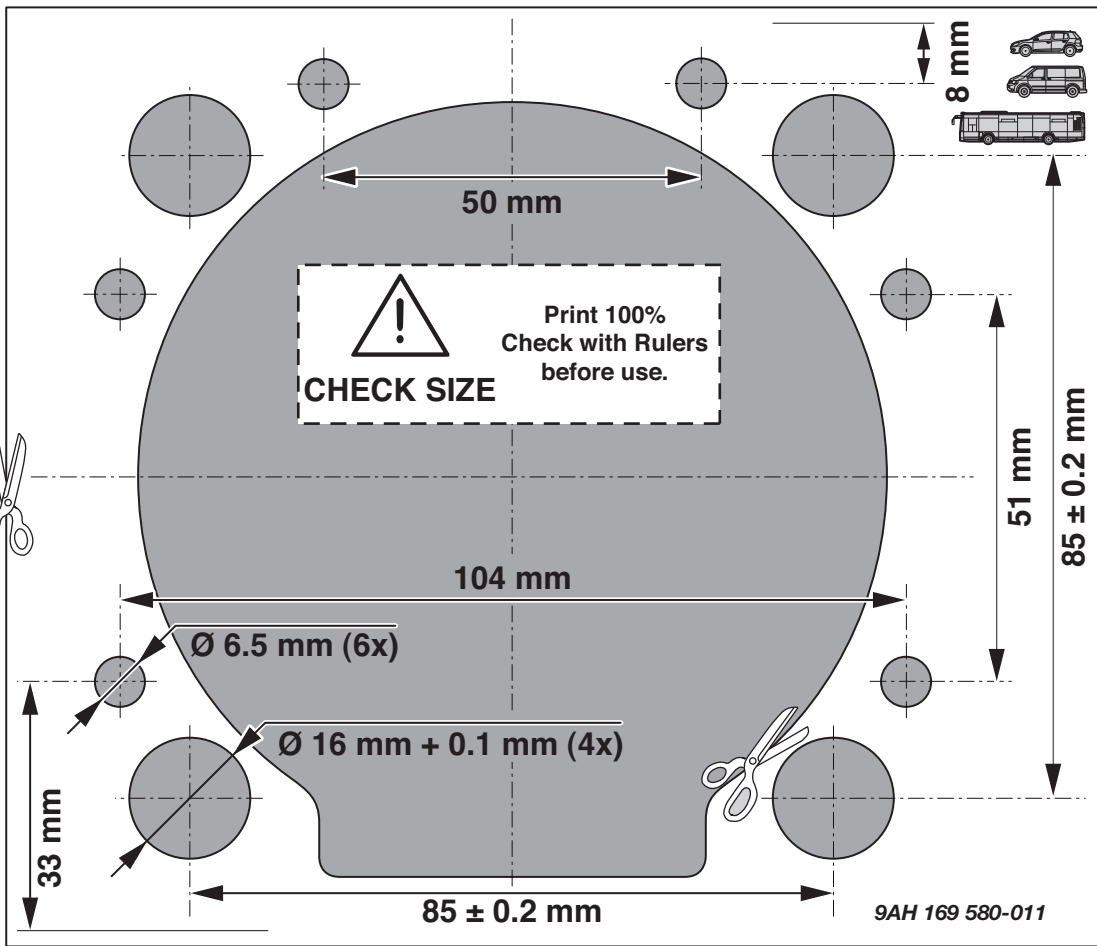
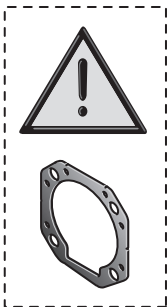

1:1

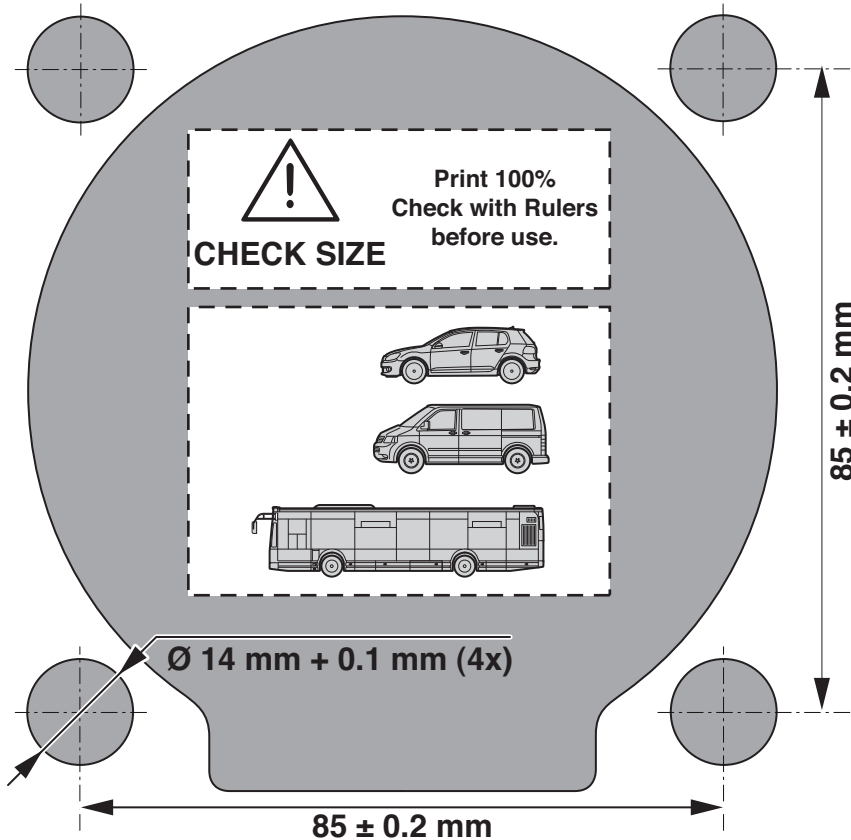
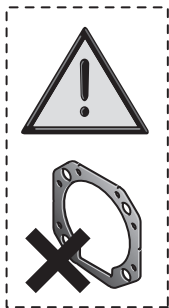

1:1

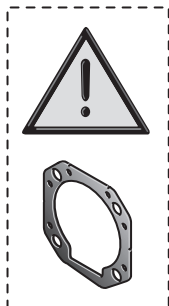

10

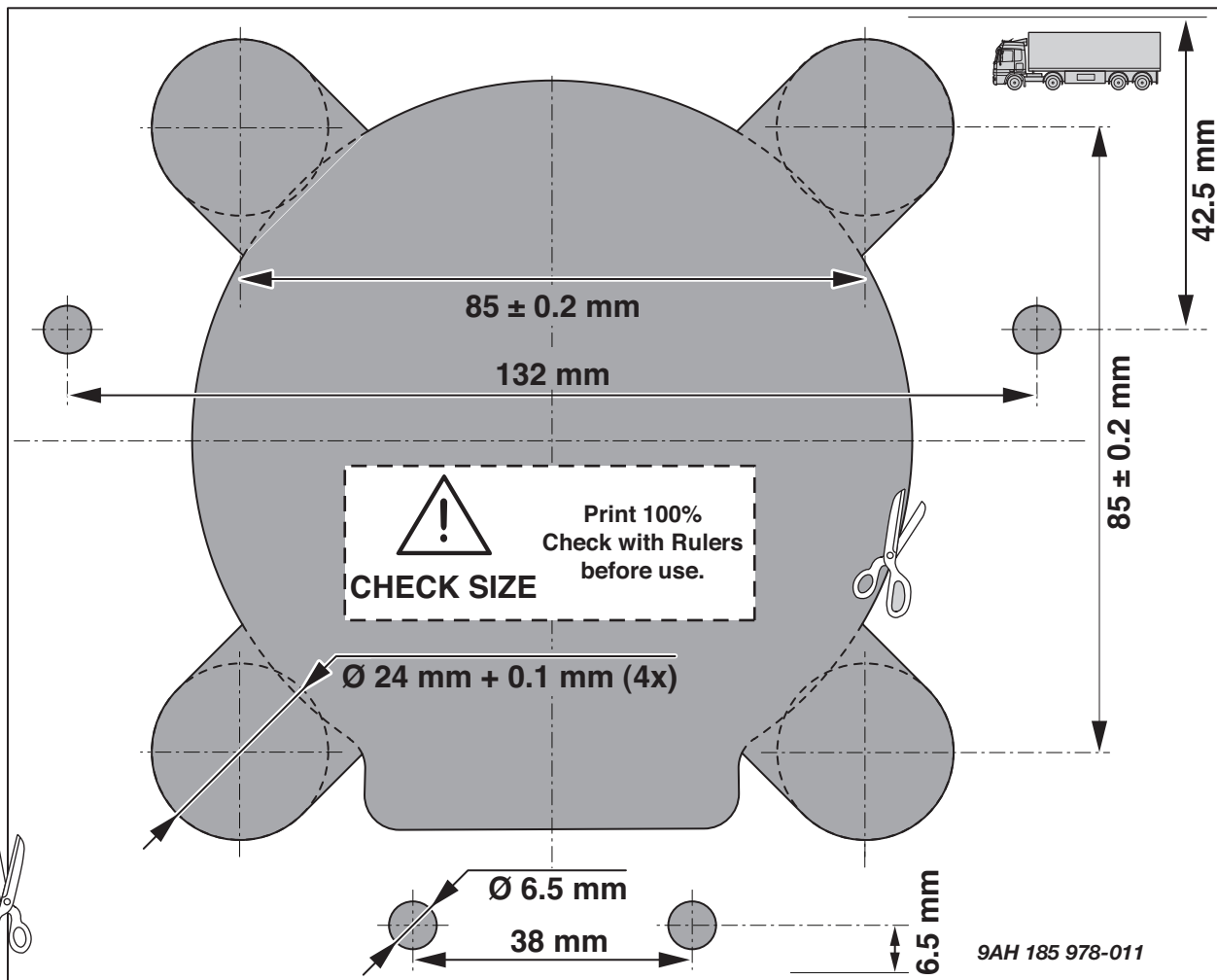

9AH 185 978-011

1:1

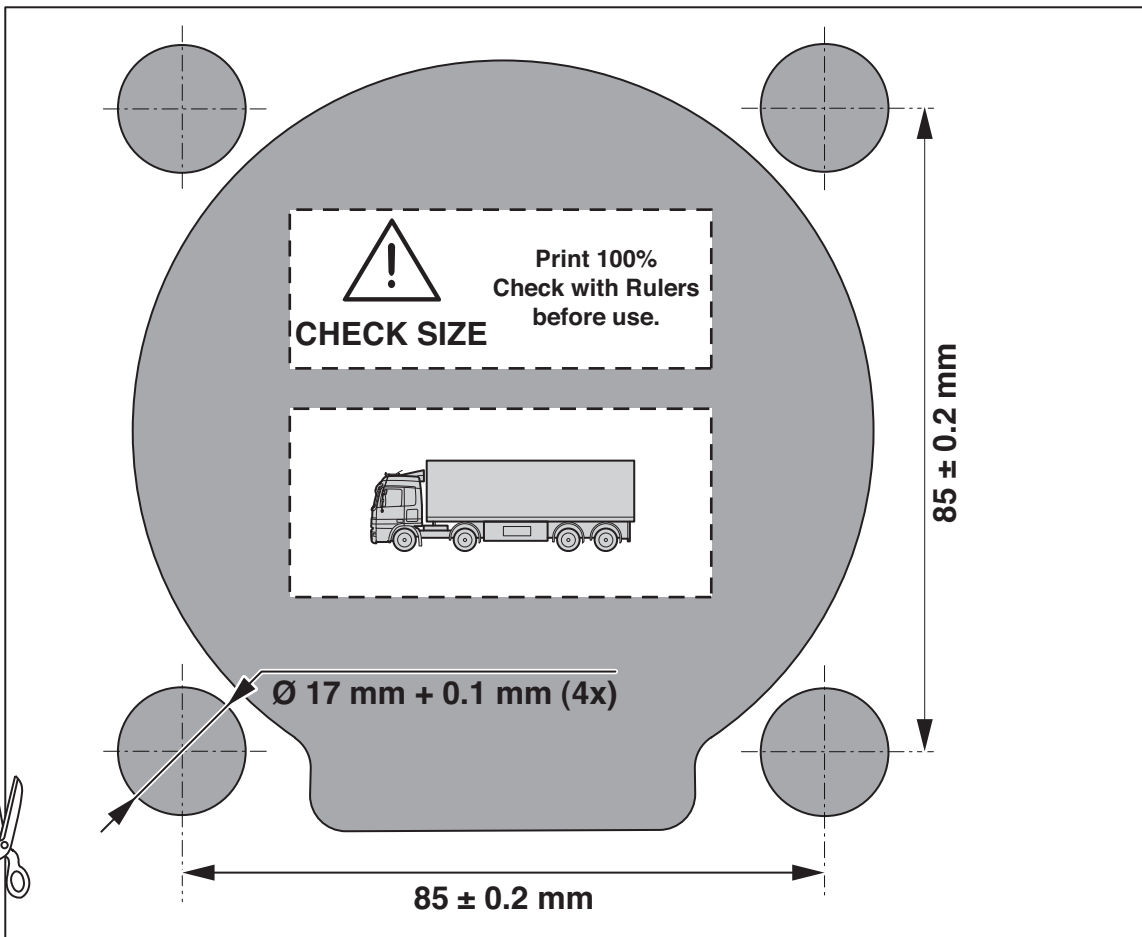
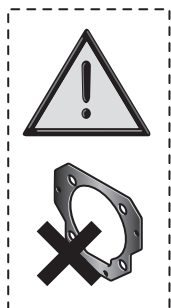

1:1

CHECK SIZE
Print 100%
Check with Rulers
before use.

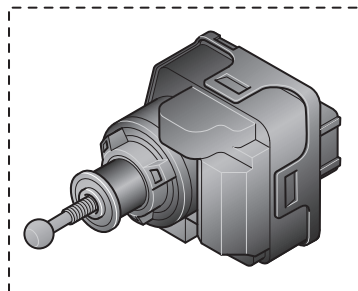
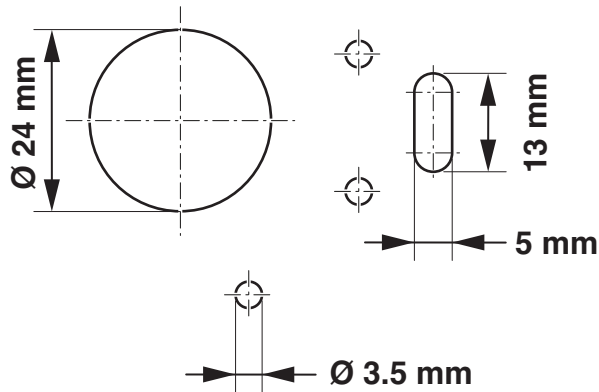

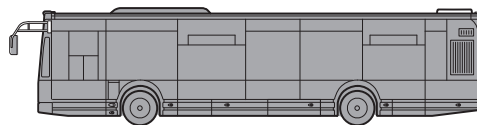
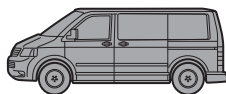
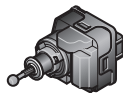
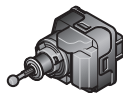

➔ **14 - 18**

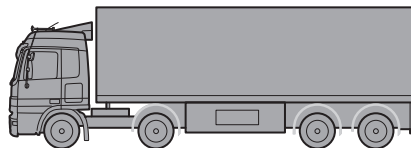

➔ **19 - 23**

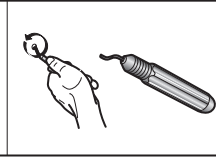
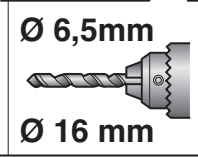
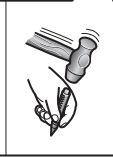
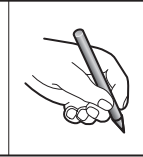
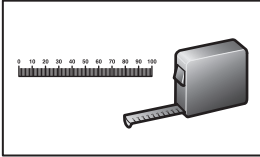
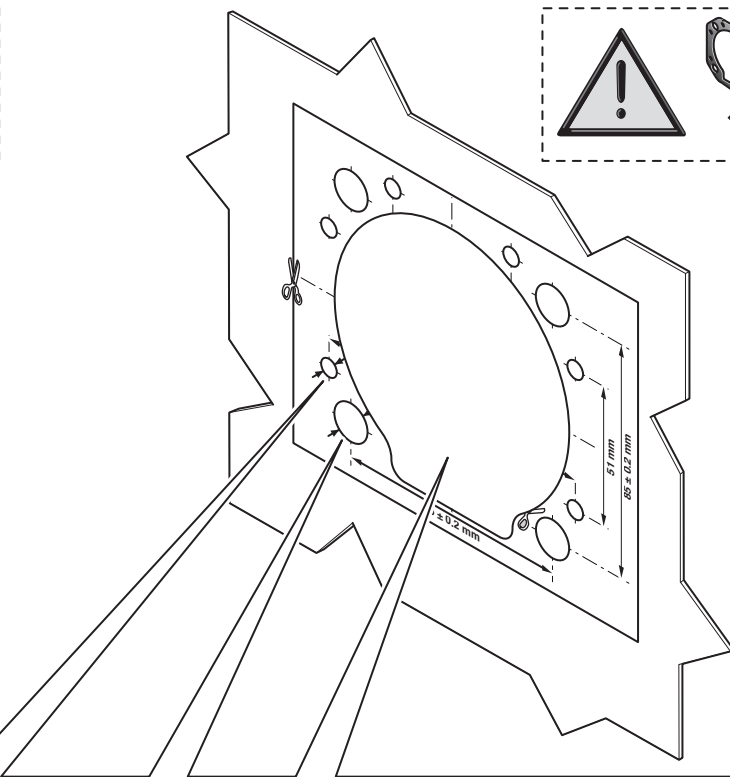
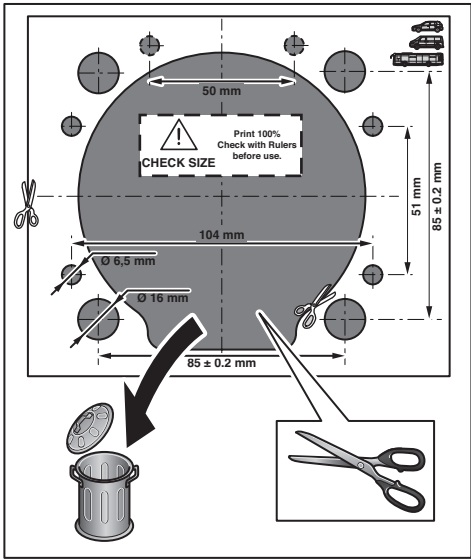
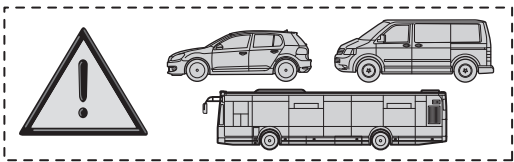

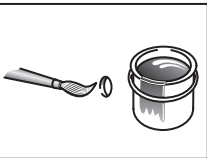
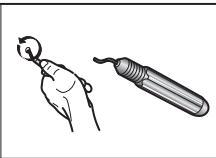
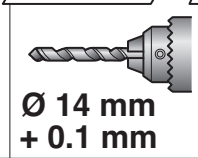
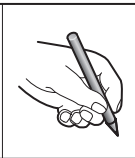
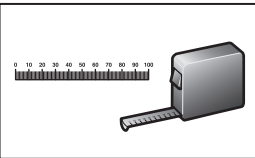
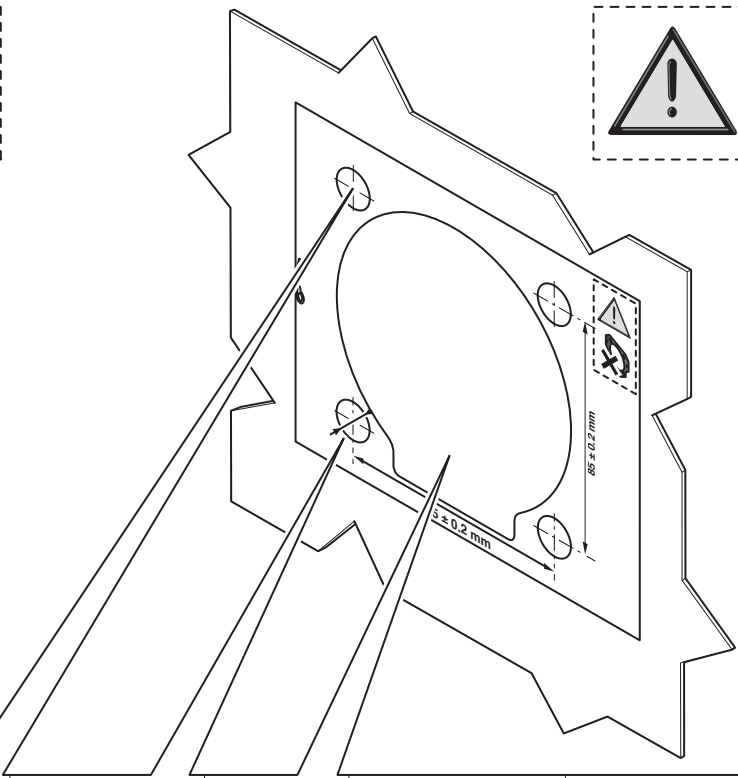
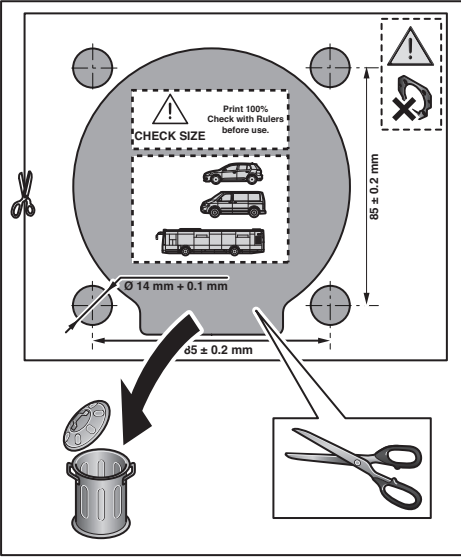
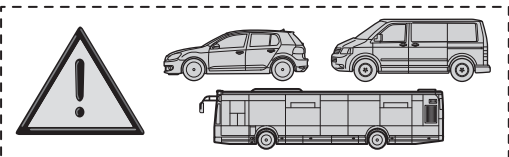

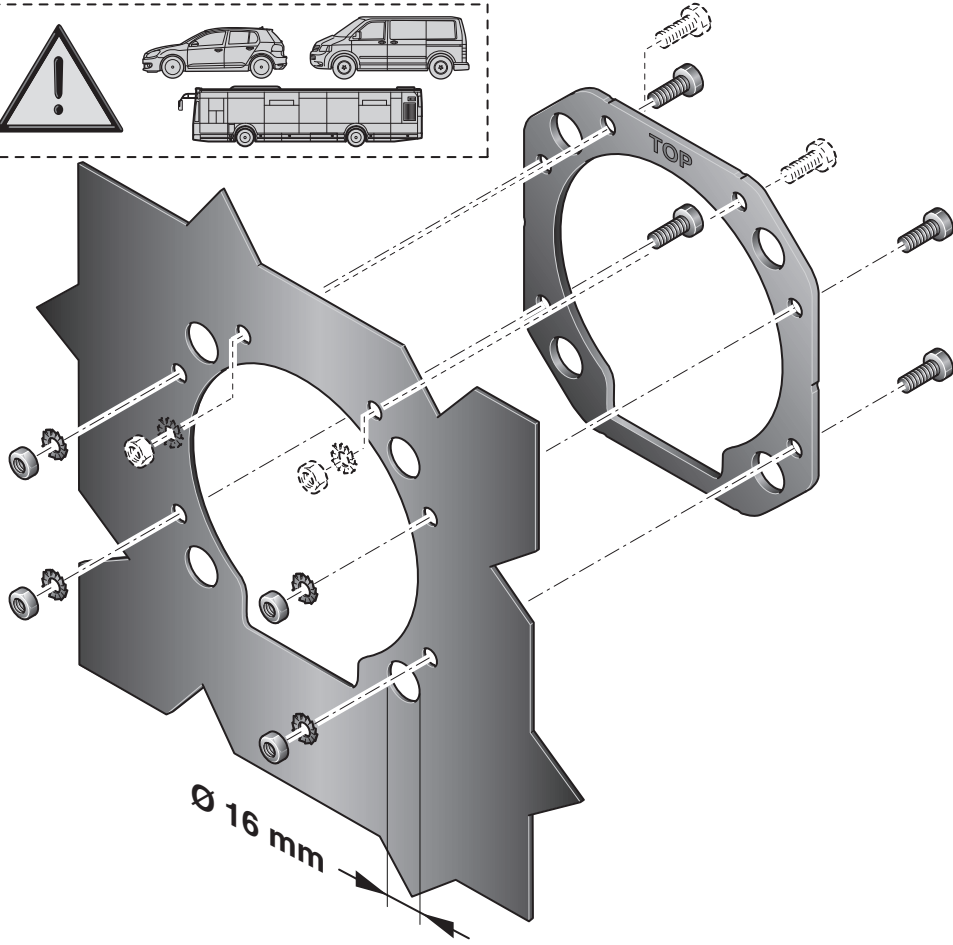
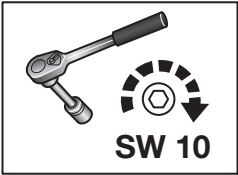
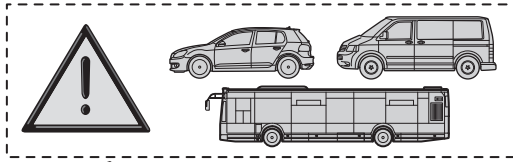

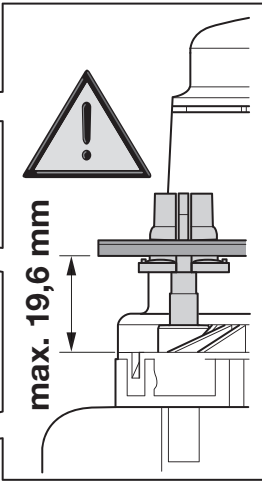
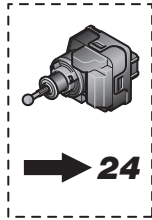
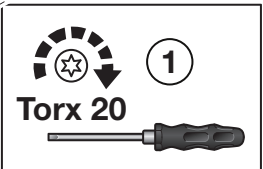
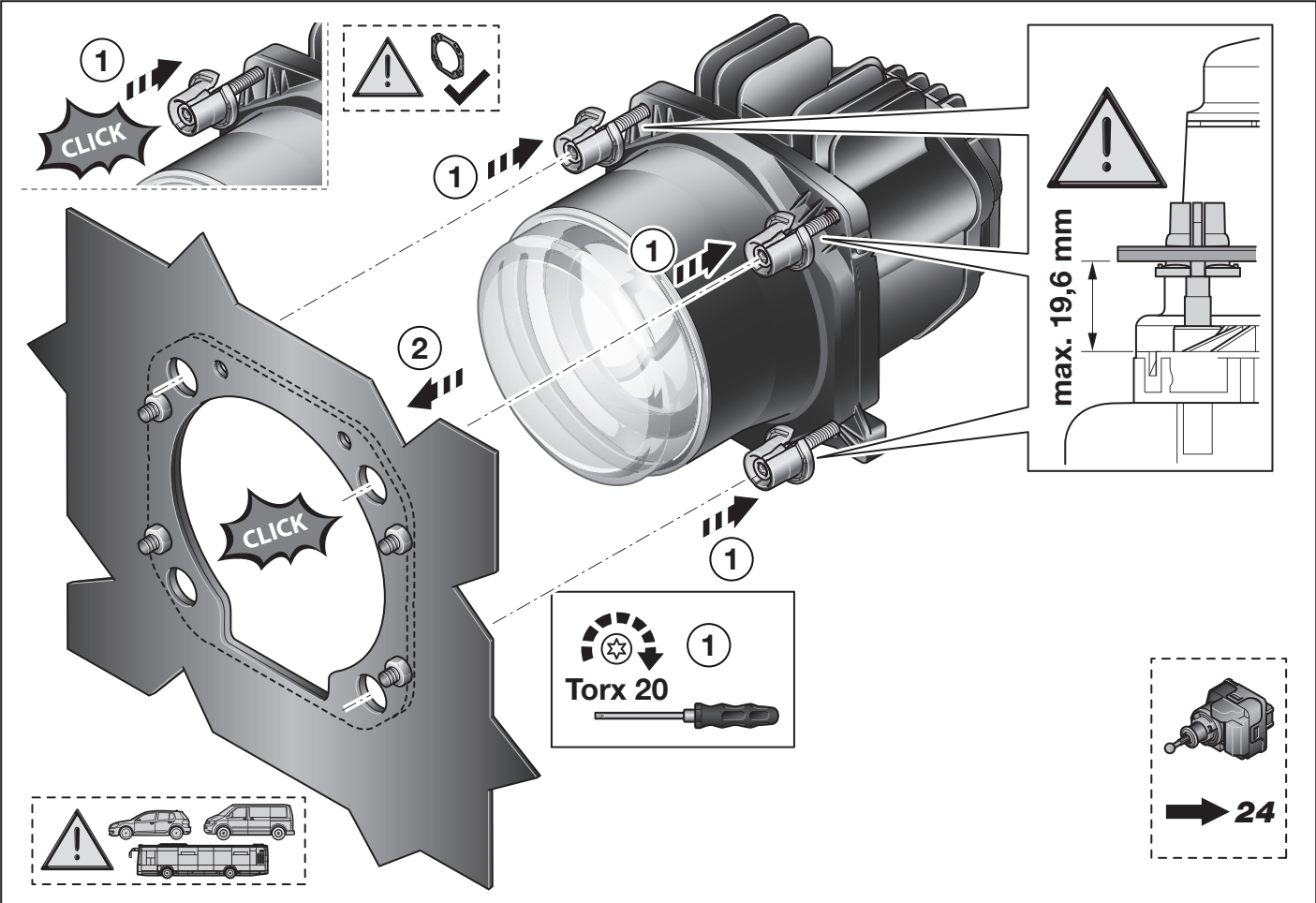

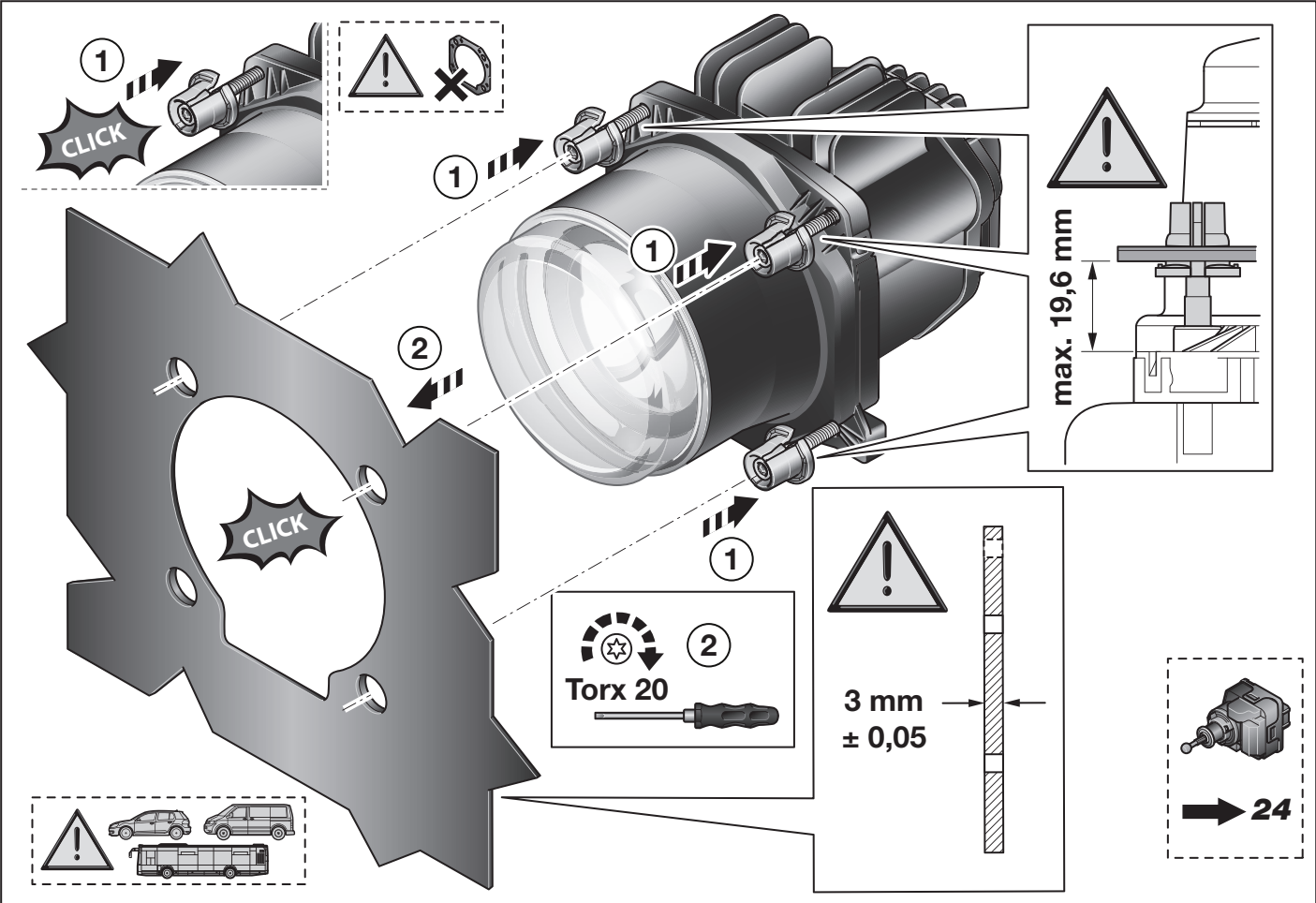

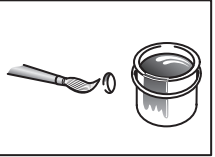
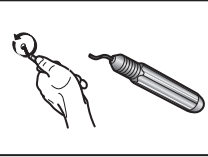
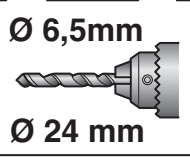
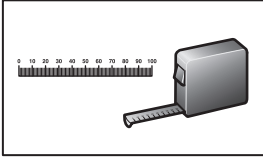
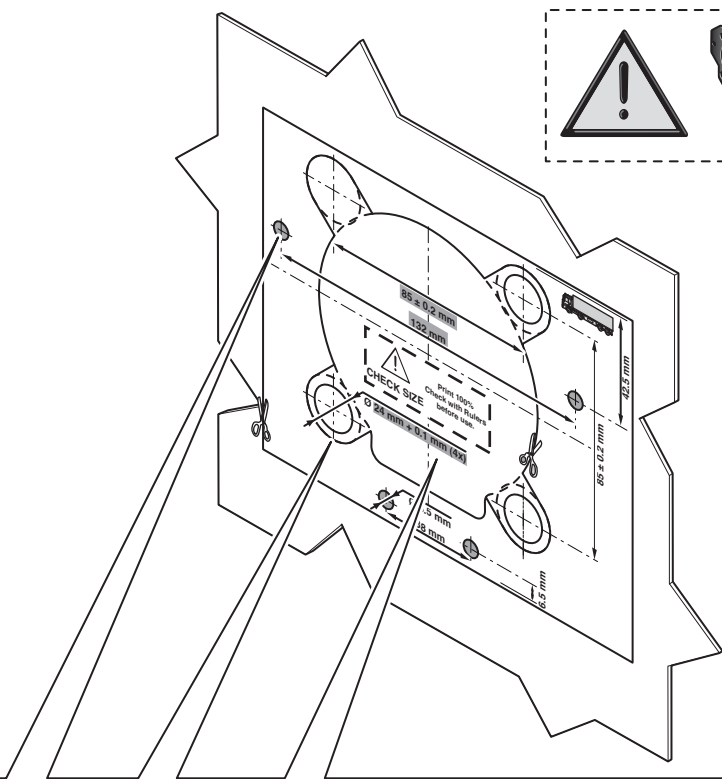
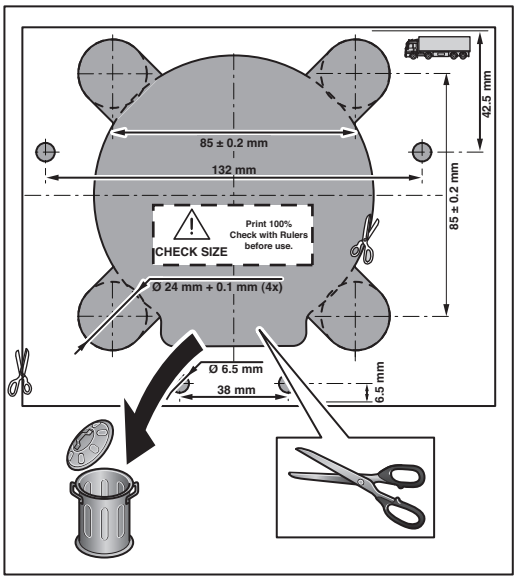
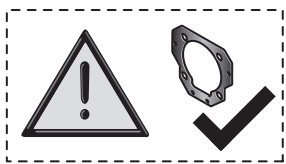
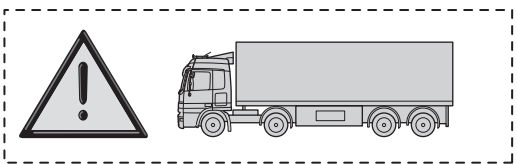

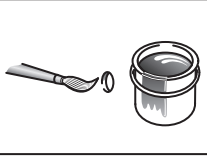
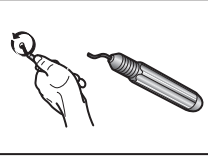
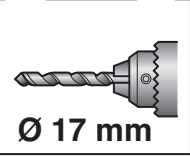
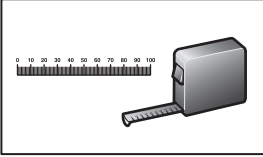
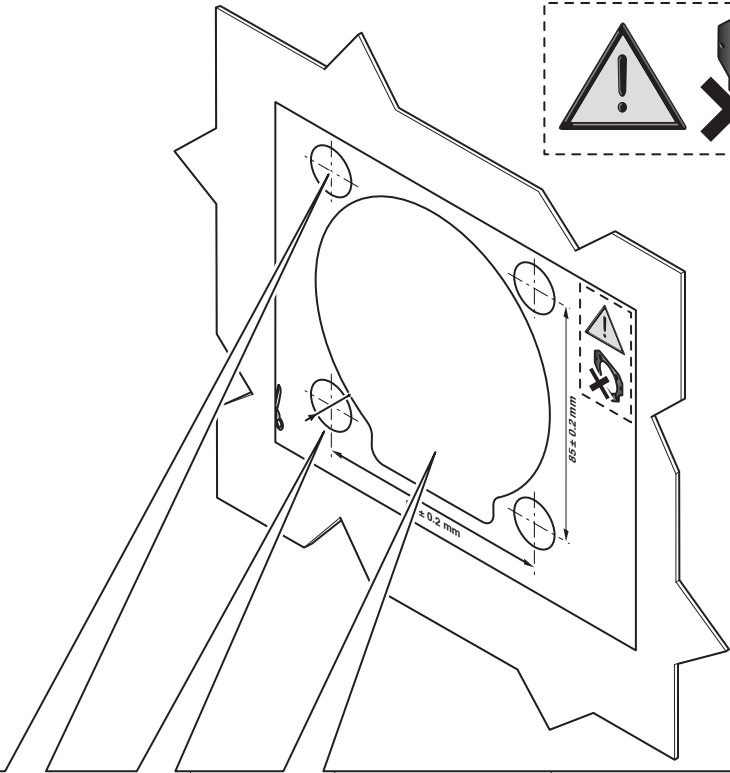
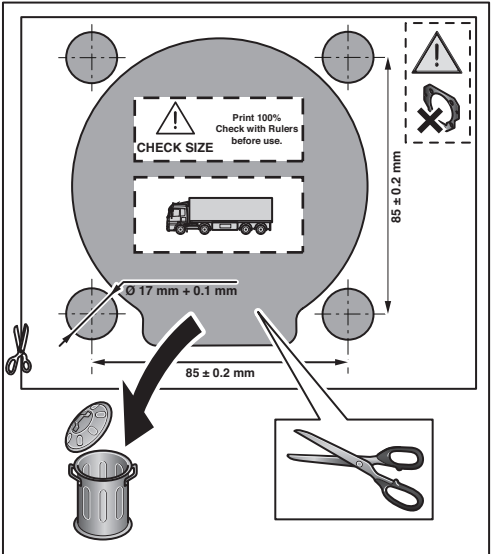
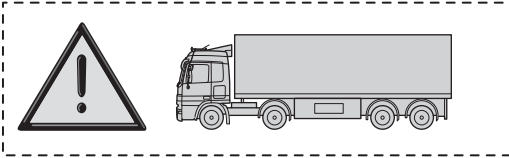

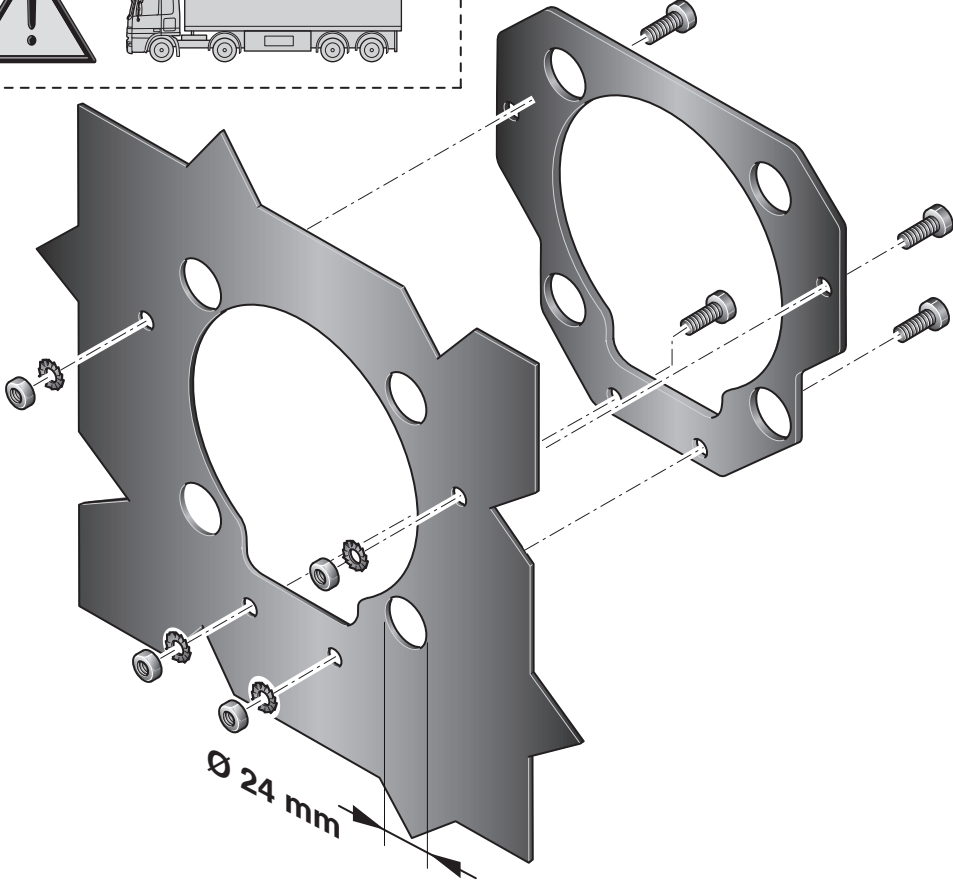
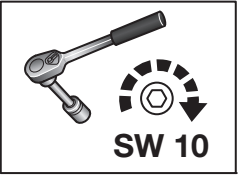
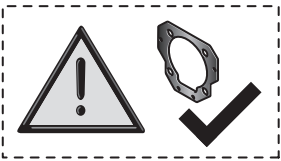
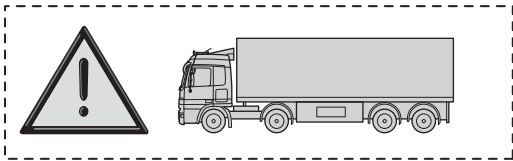

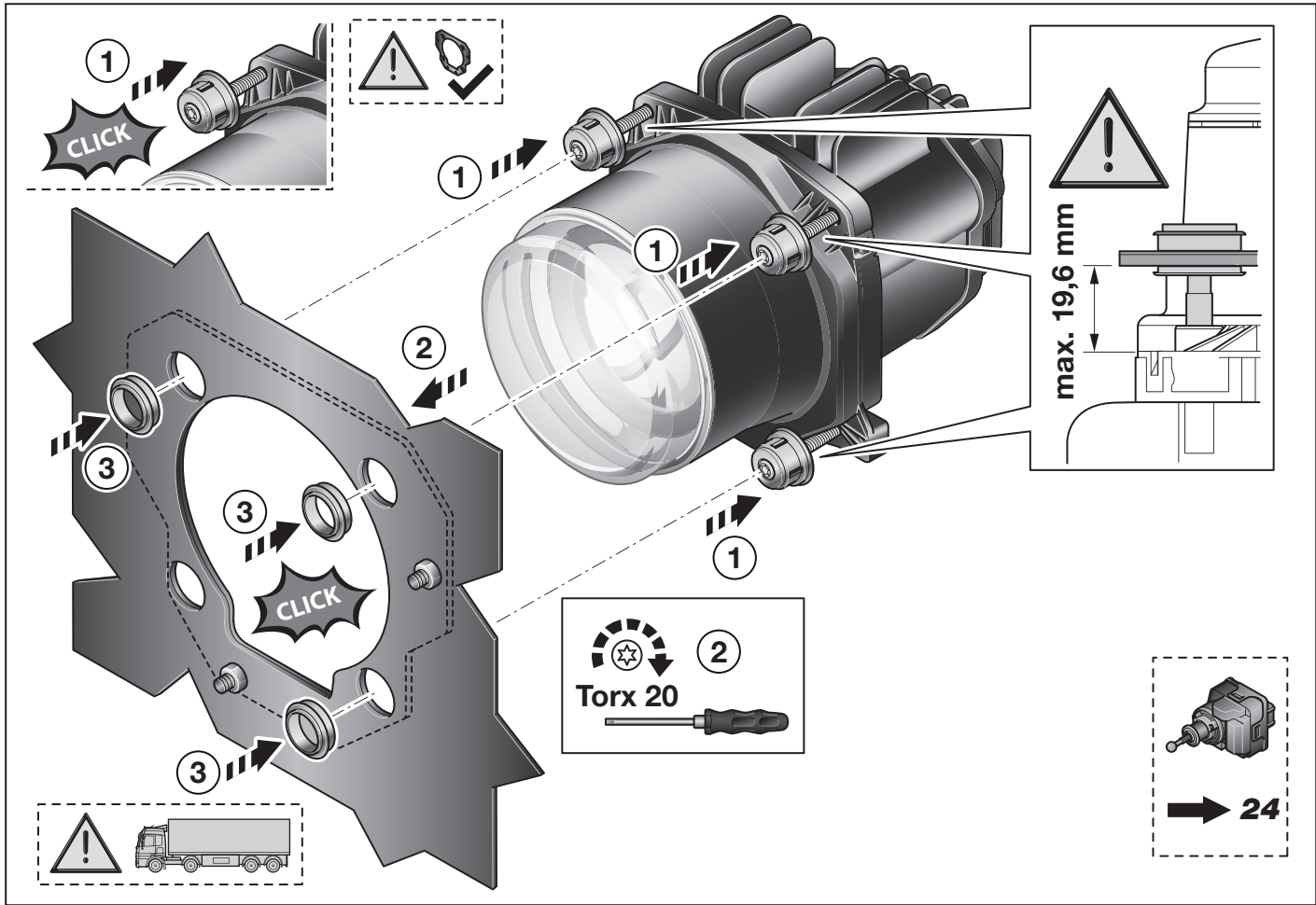

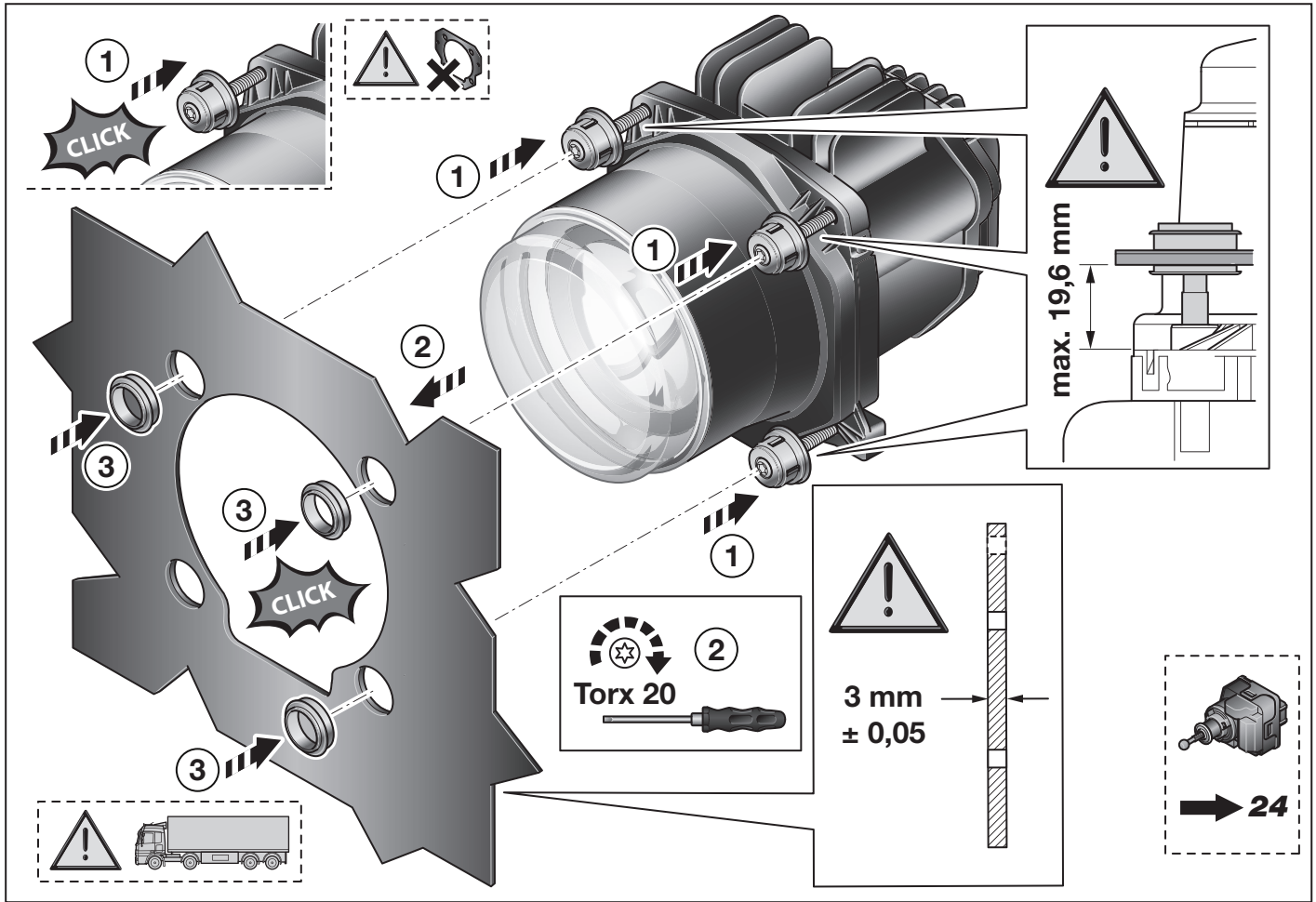

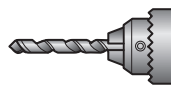
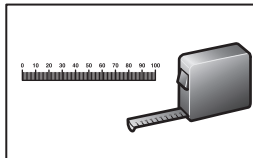
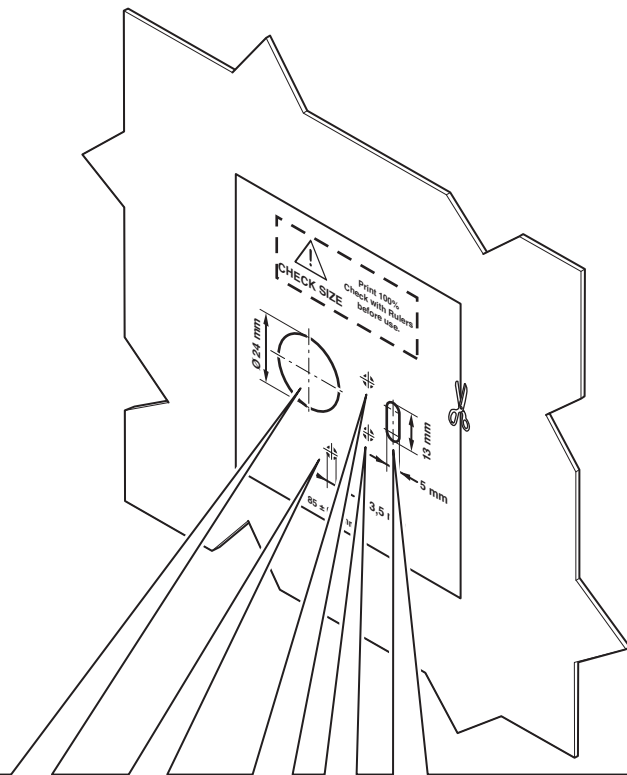
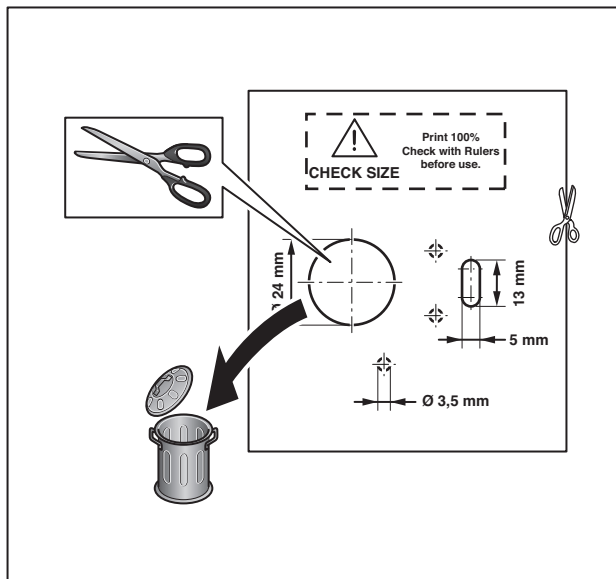

Ø 3,5 mm
Ø 5 mm
Ø 24 mm



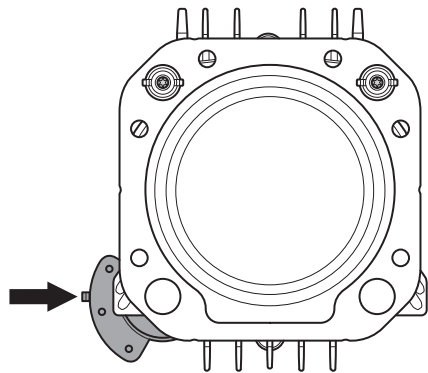

8HG 138 620-007

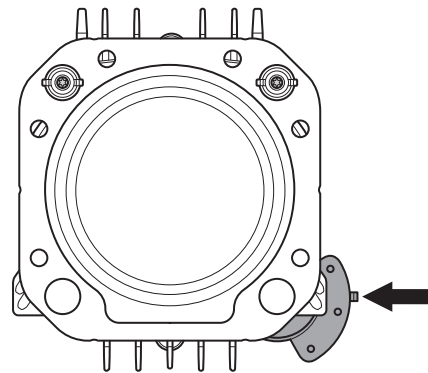
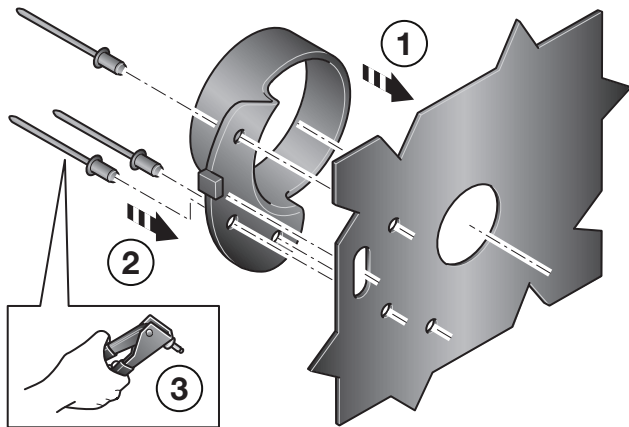

8HG 138 619-007

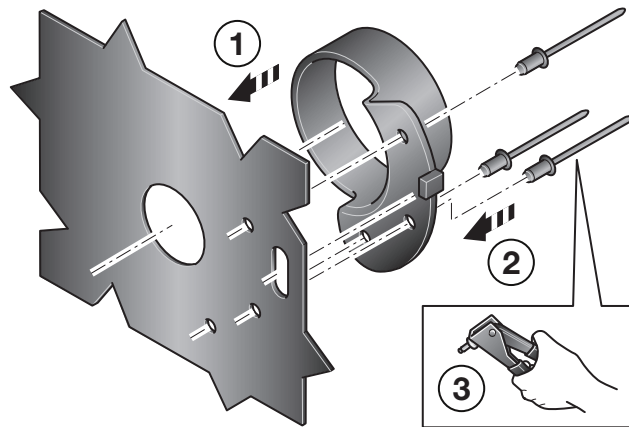

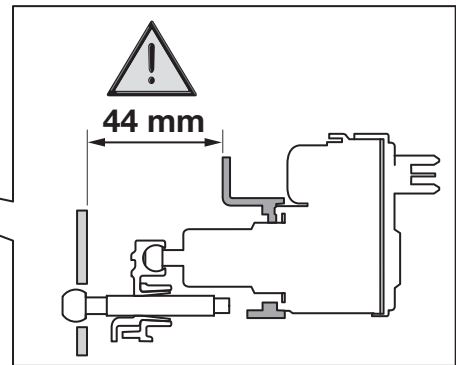
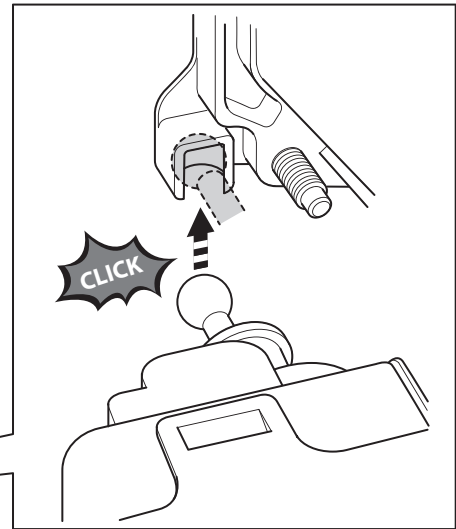
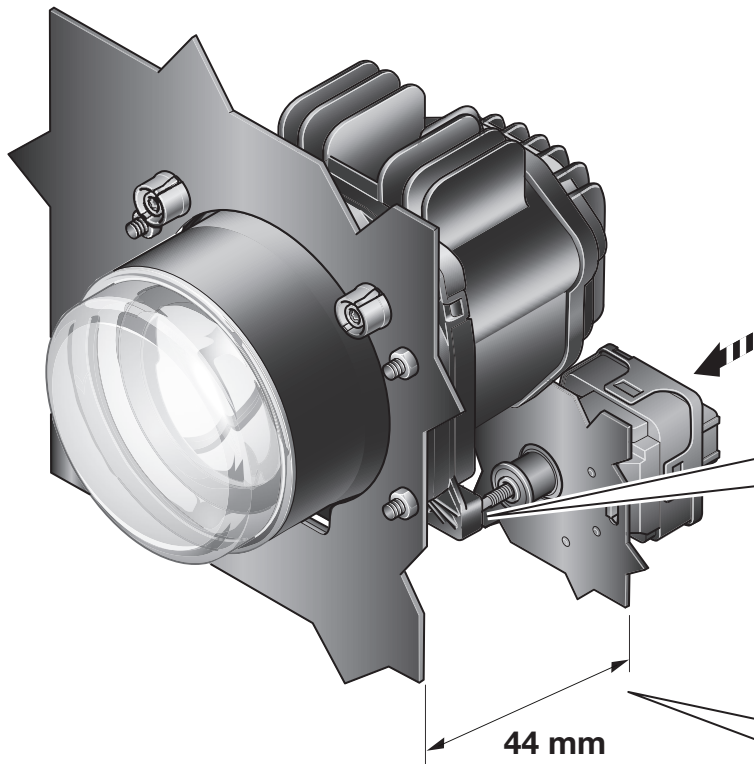

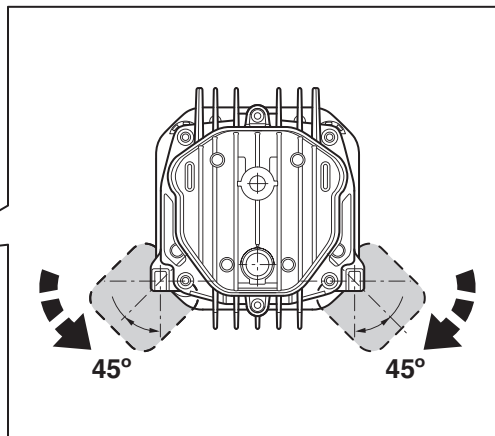
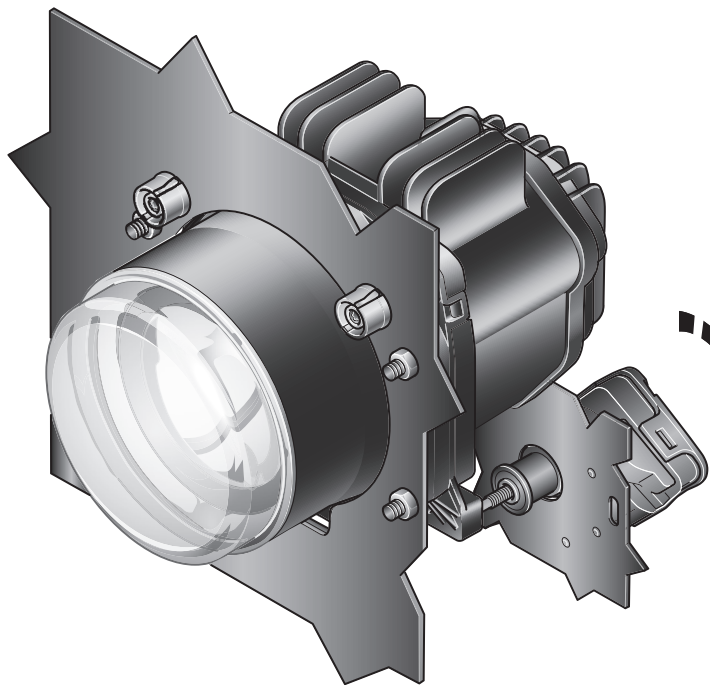

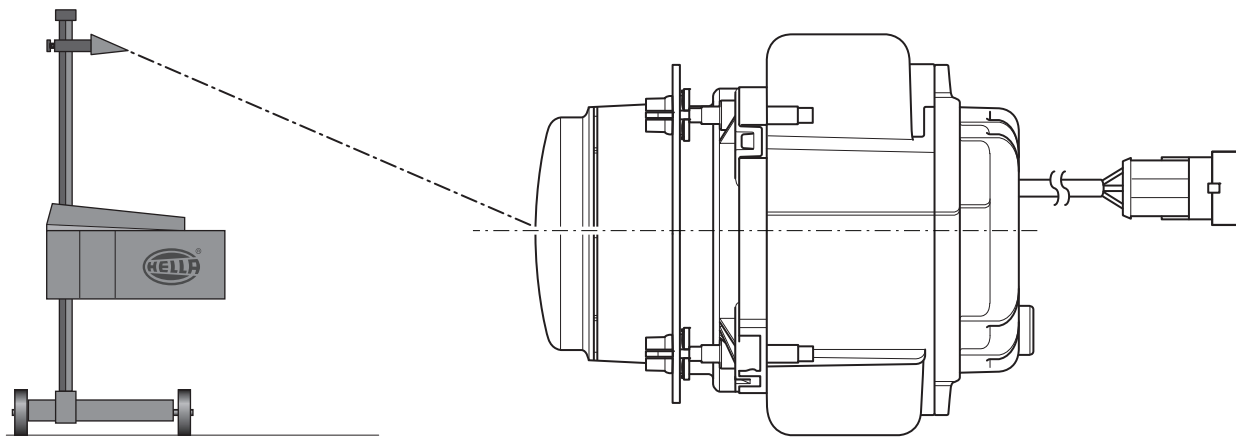
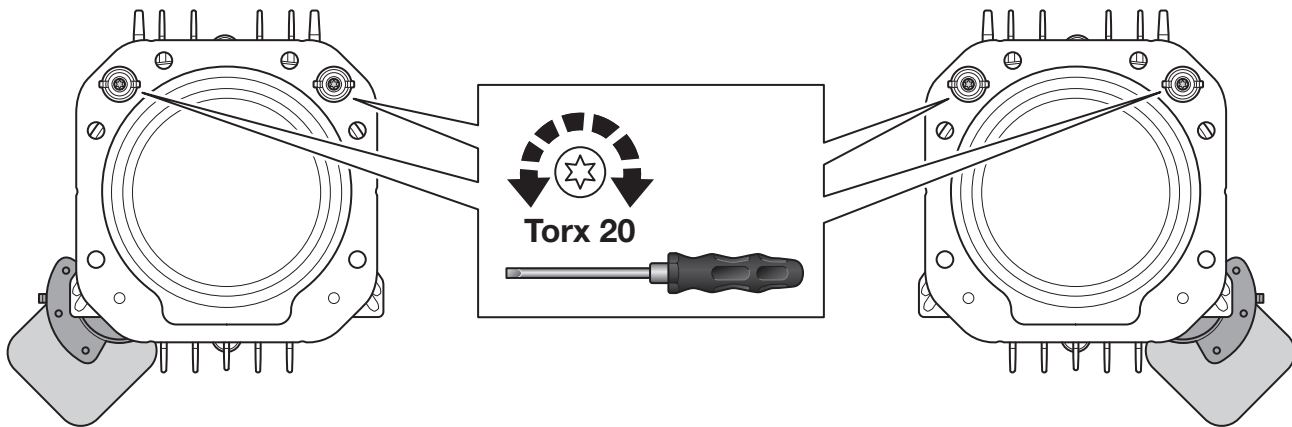

Elektrischer Anschluss
Electrical connection
Branchement électrique

Elektrisk anslutning
Elektrische aansluiting
Conexión eléctrica

Collegamento elettrico
Osaluettelo

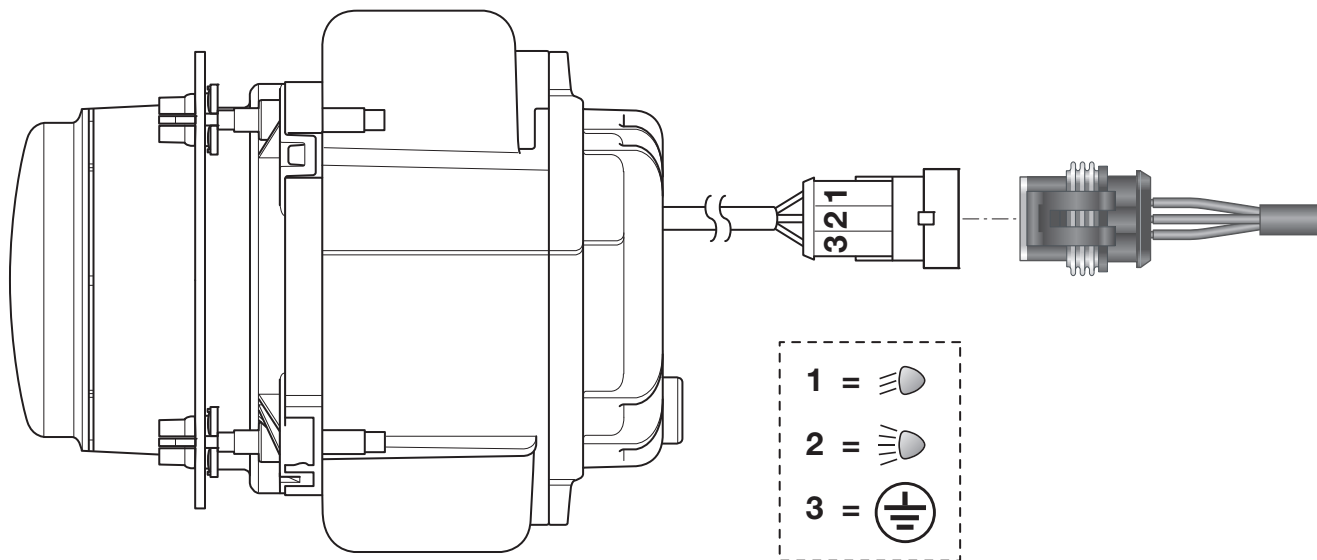

DE Für die Lichthupen- und Fernlichtfunktion müssen Ablend- und Fernlicht zusammen eingeschaltet werden.

EN To use the headlight flasher and high beam function, the low and main beam lights must be switched on together.

FR Pour la fonction appel lumineux et feux de route, le feu de croisement et le feu de route doivent être allumés ensemble.

SV För att ljusstuta ska fungera tillsammans med helljus måste halv- och helljus vara inkopplade samtidigt.

NL Voor de optische alarmsignaal- en grootlichtfuncties moeten dimlicht en grootlicht beide worden ingeschakeld.

ES Para la función de luz de carretera y hacer una señal con los faros, deberán encenderse a la vez las luces de cruce y carretera.

IT Per le funzioni dispositivo segnalazione ottica e proiettori abbaglianti, le luci anabbaglianti e abbaglianti devono essere attivate insieme.

FI Kaukovalvilkkua ja kaukovalotoimintoa varten lähi- ja kaukovalot on kytkettävä samanaikaisesti päälle.

DE Informationstext	32
EN Information Text	32
FR Texte d'information	32
SV Informationstext	32
NL Informatie tekst	32
ES Texto informativo	32
IT Informazioni	33
FI Ohjetekstit	33

DE DEUTSCH

Abblendlicht:	max. 35 W
Fernlicht:	max. 35 W
Sicherung Abblendlicht:	5 A
Sicherung Fernlicht:	5 A
Betriebsspannung:	9-32 V
Max. Betriebstemperatur:	+50 °C

Die im Geltungsbereich der ECE R48 gesetzlich geforderte Ausfallkontrolle für den LED Scheinwerfer ist im Fahrzeug durch geeignete Maßnahmen sicherzustellen.

* Das Maß muss umlaufend um das Modul eingehalten werden.

FR FRANÇAIS

Feux de croisement:	max. 35 W
Feu de route:	max. 35 W
Fusible Feux de croisement:	5 A
Fusible Feu de route:	5 A
Tension de service:	9-32 V
Max. Plage de températures:	+50 °C

La norme ECE R48 impose le montage d'un témoin de panne dans le véhicule lors de l'installation de projecteurs à DEL. Prendre les dispositions nécessaires pour satisfaire à la norme.

* La dimension doit correspondre à la périphérie du module.

NL NEDERLANDS

Dimlicht:	max. 35 W
Grootlicht:	max. 35 W
Zekering Dimlicht:	5 A
Zekering Grootlicht:	5 A
Bedrijfsspanning:	9-32 V
Max. Temperatuurbereik:	+50 °C

De in het toepassingsbereik van de ECE R48 wettelijk vereiste uitvalcontrole voor de LED koplamp dient in het voertuig door de juiste maatregelen te worden gewaarborgd.

* De maat moet rondom de module worden aangehouden.

EN ENGLISH

Low Beam:	max. 35 W
High Beam:	max. 35 W
Fuse Low Beam:	5 A
Fuse High Beam:	5 A
Operating Voltage:	9-32 V
Max. Operating temperature range:	+50 °C

The legally required failure indicator stipulated in the ECE R48 regulation for the LED headlights is to be mounted in the vehicle. Take the necessary precautions in order that these regulations are met.

* The gauge must be kept circulating around the module.

SV SVENSKA

Halvljus:	max. 35 W
Helljusstrålkastare:	max. 35 W
Säkring Halvljus:	5 A
Säkring Helljusstrålkastare:	5 A
Driftspänning:	9-32 V
Max. Driftstemperaturområde:	+50 °C

Den felkontroll som lagen kräver för området ECE R48 för LED-strålkastare ska säkerställas i fordonet genom lämpliga åtgärder.

* Värdet måste hållas konstant för hela modulen.

ES ESPAÑOL

Luz de cruce:	max. 35 W
Luz antiniebla trasera:	max. 35 W
Fusible Luz de cruce:	5 A
Fusible Luz antiniebla trasera:	5 A
Tensión de régimen:	9-32 V
Gama de temperaturas de trabajo máx.:	+50 °C

El control de fallos que exige la ley dentro del ámbito de aplicación de la normativa ECE R48 para los faros de LED queda garantizado en el vehículo con las medidas adecuadas.

* Las dimensiones deben ajustarse al perímetro del módulo.

IT ITALIANO

Proiettore anabbagliante:	max. 35 W
Luce abbagliante:	max. 35 W
Fusibile Proiettore anabbagliante:	5 A
Fusibile Luce abbagliante:	5 A
Tensione di funzionamento:	9-32 V
Campo della temperatura di funzionamento max.:	+ 50 °C

Il controllo dei guasti prescritto per legge nell'ambito di applicazione della norma ECE R48 per il fanale a LED deve essere garantito sul veicolo mediante adeguati provvedimenti.

* La misura deve essere rispettata sull'intero perimetro del modulo.

FI SUOMI

Läihivalot:	enint. 35 W
Asennusohjeita:	enint. 35 W
Sulake Läihivalot:	5 A
Sulake Asennusohjeita:	5 A
Käyttöjännite:	9-32 V
Toimintalämpötila:	+ 50 °C

ECE R48 -standardin voimassaoloalueella lakisääteinen LED-valonheittimien toimintahäiriön valvonta on varmistettava ajoneuvoissa sopivien toimenpiteiden avulla.

* Arvoa on noudatettava moduulin ympärillä.

DE Beleuchtungsanlage auf einwandfreie Funktion hin prüfen

EN Check that the lighting system is working perfectly

FR Contrôler le bon fonctionnement de l'installation d'éclairage

SV Kontrollera att ljussystemet fungerar felfritt

NL Controleer of de verlichting goed functioneert

ES Comprobar que el sistema de iluminación funciona impecablemente

IT Controllare la perfetta funzionalità dell'impianto di illuminazione

FI Tarkasta valaistusjärjestelmän toiminta

DE Bei Fragen oder Einbauproblemen, rufen Sie bitte den HELLA Kundendienst, Großhändler an oder wenden Sie sich an Ihre Werkstatt.

EN If you have questions or installation problems, please call the HELLA Service, wholesaler, or turn to your garage.

FR Pour toutes questions ou problèmes de montage, merci de contacter le service après-vente HELLA, votre distributeur ou votre garage.

SV Vid frågor eller monteringsproblem, kontakta Hella kundtjänst, återförsäljaren eller din verkstad.

NL In geval van vragen of montageproblemen verzoeken wij u contact met de HELLA-klantenservice, de groothandel of uw dealer op te nemen.

ES En caso de dudas o problemas de montaje, por favor, llame al Servicio postventa de Hella o al mayorista, o bien diríjase a su taller.

IT Per qualsiasi domanda o problemi di montaggio si prega di contattare il servizio assistenza o il proprio grossista HELLA oppure di rivolgersi alla propria officina.

FI Jos sinulla on kysymyksiä tai asennusongelmia, soita HELLA-asiakaspalvelulle tai tukkuliikkeelle tai käänny korjaamon puoleen.

